

# FELINS

# ATS

## MS-420

The **MS 420** offers superior reliability in a tabletop model. This light weight portable unit provides reliable heat seal banding using paper or plastic materials.

### Quick and Easy to Use

The ease of operation, material changing and versatility of using paper or plastic material, make the MS-420 ideal for a wide variety of bundling applications. Material is also available in color and can be imprinted.

Freely adjustable tension allows bundling of a variety of products without damage to edges.

Impulse heat seal technology enables immediate use, there is never a need to pre-heat the unit. The MS-420 has the capabilities of banding up to 25 bundles per minute.

### Tabletop or Stand-Alone

The machine is available in both a tabletop version or on a stand. The **MS-420S** comes with a large roll dispenser stand, allowing for fewer material changes. The motorized dispenser eliminates drag as the material is drawn into the machine. The stand's adjustable height feature allows the unit to be integrated into most production settings.



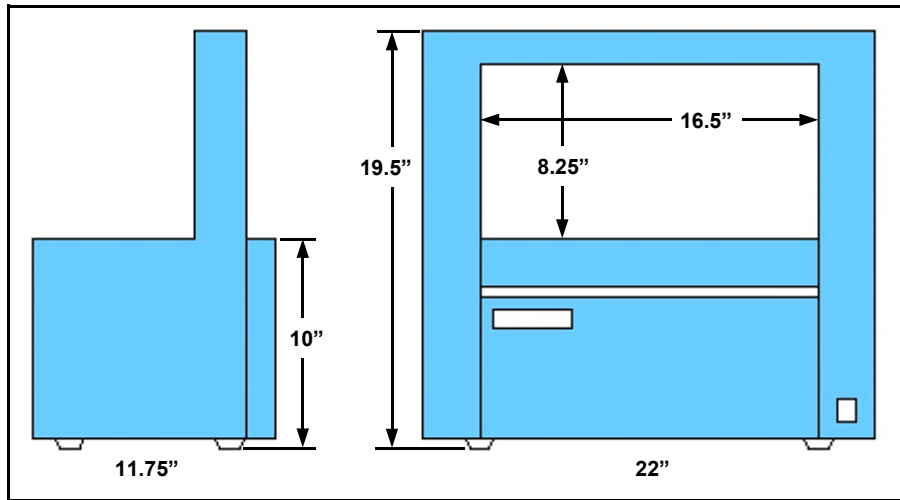

### Specifications

#### Bander:

Product Bundle Sizes	30-400mm (W) x 10-200mm (H)
Cycle Speed	25 Bundles per Minute
Tape Width	30mm
Bundling Tension	Freely Adjustable
Dimensions	See above diagram
Power Requirements	110 or 220 VAC, 50/60 Hz
Power Consumption	200W
Weld Method	Impulse Heater
Net Weight	70 lbs.

#### Stand/Dispenser:

Dimensions: (Length/Width)	26" x 18"
Height Minimum	19"
Height Maximum	28"
Power Requirements	110 or 220 VAC, 50/60 Hz
Power Consumption	200W



*For more information and pricing, contact Felins Incorporated at*

**1-800-336-3220**

8306 W. Parkland Court • Milwaukee, Wisconsin, 53223 • Tel. 414-355-7747 • Fax 414-355-7559

Internet [www.felins.com](http://www.felins.com) • E-Mail [sales@felins.com](mailto:sales@felins.com)